

A-A

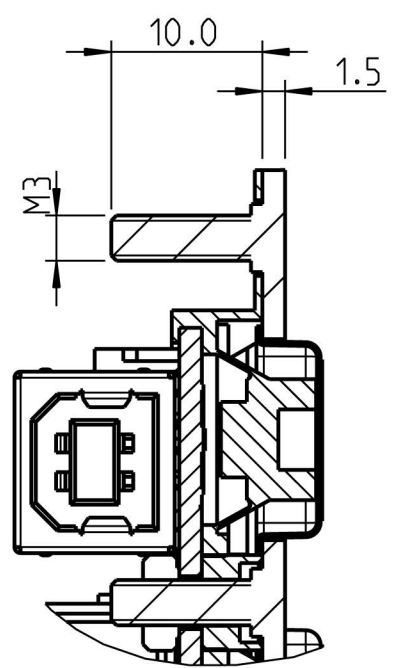

A
2:1

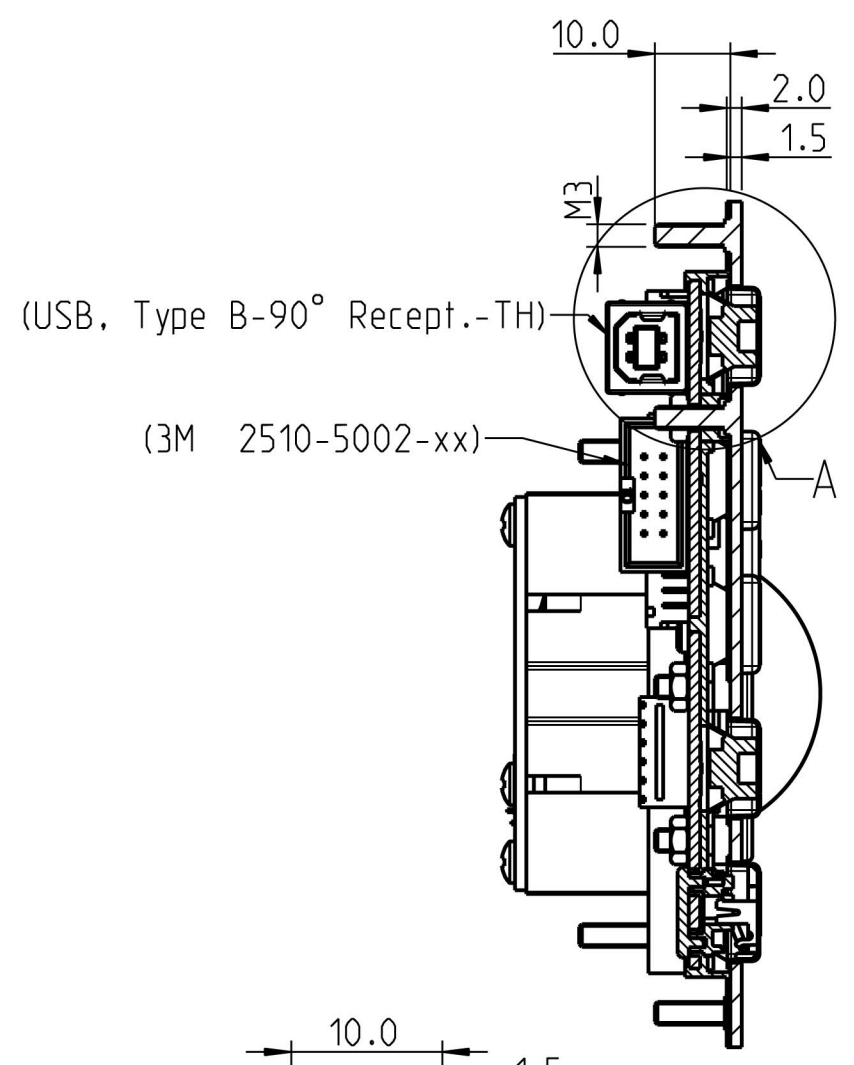
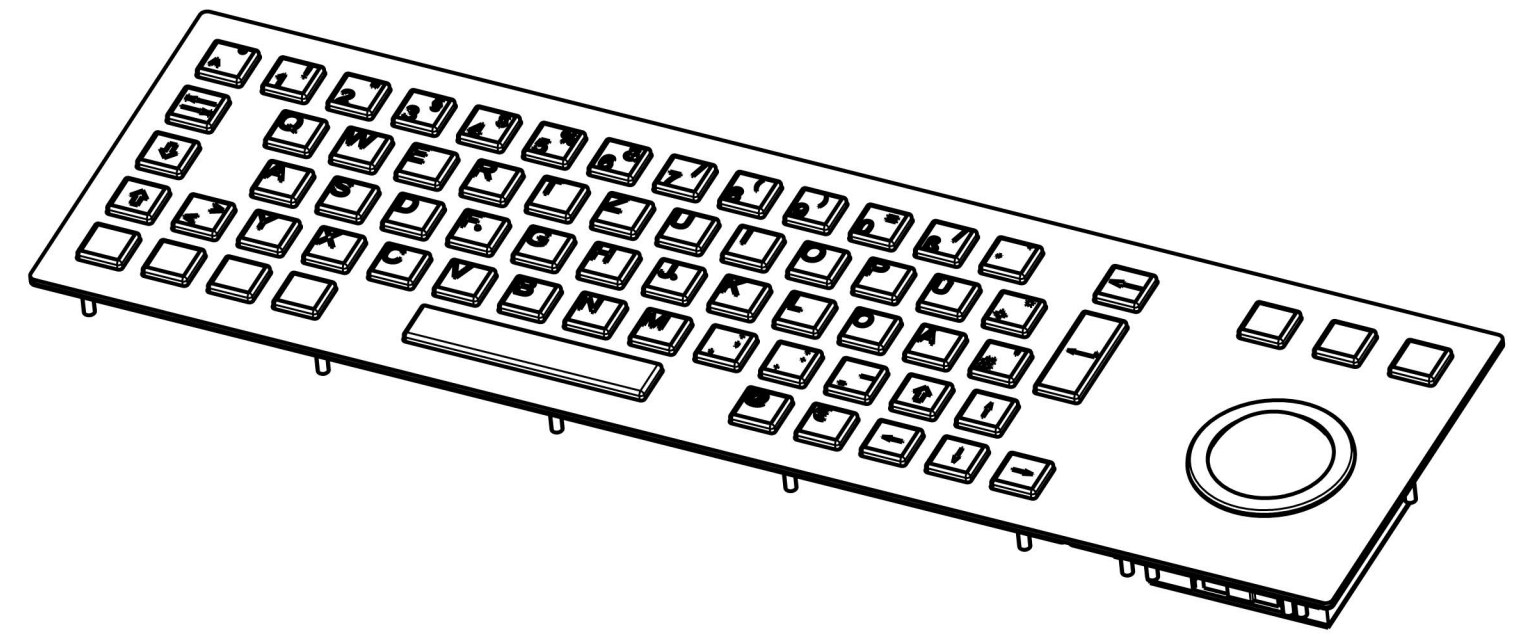

1:2

Aenderungen vorbehalten		Prüfmaß WEK		Anzahl:
P1	angepasst	03.08.09	UH	
PO	neu	27.02.09	UH	
Zust.	Aenderung	Datum	Name	
Bearb.	27.02.09	UH		
Gepr.				
Norm				
	Datum	Name		

Projekt:		
Material	-	
Halbzeug	-	
Lieferant	-	
Massstab	1:1	Menge
Benennung		
Tastatur.		
Werkzeug-Nr.	Zeichnung-Nr.	Blatt 1
-	-	von 1 Bl.
Ers. f.	Ers. d.	A2